

LocalSolver

& la Recherche Opérationnelle chez Bouygues

Frédéric Gardi



fgardi@localsolver.com



Objectifs

Découvrir des applications concrètes des techniques de recherche opérationnelle et d'aide à la décision

Avoir un retour d'expérience méthodologique sur la résolution de problèmes d'optimisation en milieu industriel

Découvrir et utiliser un solveur nouveau : LocalSolver, solveur d'optimisation mathématique hybride



LocalSolver

Filiale Optimisation & Aide à la Décision du Groupe Bouygues

10 ingénieurs-docteurs en informatique et mathématiques

20 ans d'expérience en Recherche Opérationnelle

- Optimisation
- Planification
- Prévion
- Revenue management
- Analyse de données
- Simulation
- Règles métier

+ un solveur innovant
d'optimisation mathématique

 **LocalSolver**
www.localsolver.com

 Conseil
Logiciels
LocalSolver

Une offre logicielle concentrique

Problème métier

Modèle

Solution

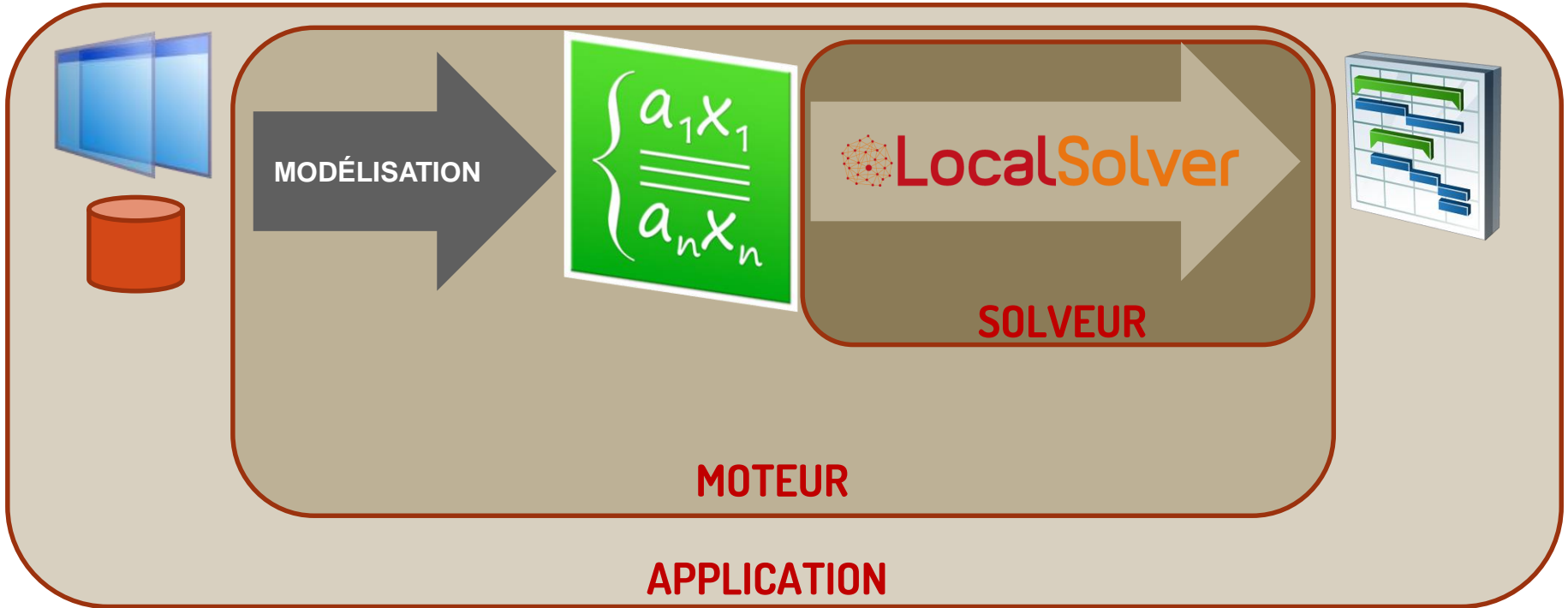

Bouygues

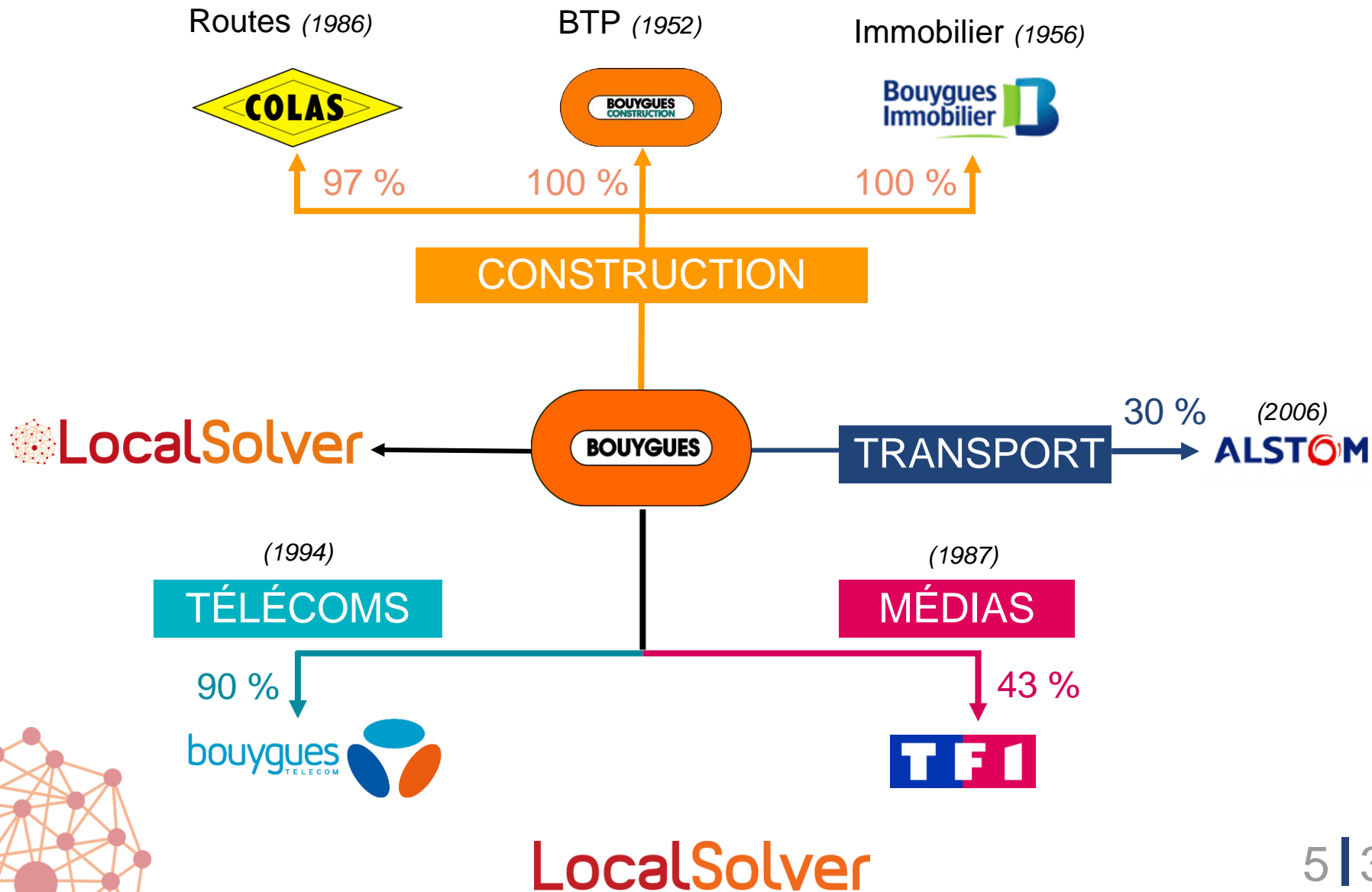

Des clients dans tous les métiers

- Construction    
- Medias & Advertising     
- Telco & Retail    
- Large Industry     
- Energy     
- Banking & Finance    
- Transportation   
- Logistics    
- Food & Agribusiness    
- Aerospace & Defense    
- IT Services      

Des clients à l'international

30 clients en France

dont 20 clients au CA > 1 Mds €

30 clients à l'international

Allemagne, UK, Belgique, Italie,
Danemark, Suède,
USA, Canada, Japon, Chine

20 universités et écoles

France, Allemagne, Belgique,
Italie, Portugal, USA, Japon,
Chine, Brésil

 Central Entity (fr)	 Airbus Operations (fr)	 ALF (fr)	 ORCO (fr)	 Future Architect (jp)	 Hitachi YRL (jp)	 Helmut Schmidt U. (de)	 Heron Normal U. (cn)
 Altran Prime (fr)	 A-SIS (fr)	 Bacallan (jp)	 Bouygues CAS (fr)	 Horosphere (ca)	 Inner Mongolia N. U. (cn)	 INSA Rennes (fr)	 IT-CE (fr)
 Bouygues Immobilier (fr)	 Bouygues Telecom (fr)	 Bouygues SA (fr)	 CLAI (it)	 Kagawa Prefecture (jp)	 Kyoto University (jp)	 LAC (it)	 Nanjing University (cn)
 University of Coimbra (pt)	 Colas (uk)	 Leeds, CU-Boulder (us)	 Dongbei University (cn)	 NIES (jp)	 MEDA (fr)	 Media Transports (fr)	 Medavision (fr)
 DTP (fr)	 Eco-Management (fr)	 EDF R&D (fr)	 EdgeStone IT (cn)	 Mereo (fr)	 Me University (jp)	 MSI (jp)	 Osaka University (jp)
 Electric 80 (it)	 EMBIX (fr)	 ORIGN (fr)	 ESIEE Paris (fr)	 Osaka University (jp)	 Pasco Shikishima (jp)	 Renault (fr)	 LFRN (br)
 Eurodecision (fr)	 French Army (fr)	 Fujitsu Laboratories (jp)	 Fujitsu Sit. (jp)	 Rovi Corporation (us)	 Senshu University (jp)	 Shanghai Jia Tong U. (cn)	 SNCF Réseau (fr)
 Timeplus (fr)	 Universal Studios (jp)	 VDR (fr)	 Zhongnan University (cn)	 Socio Logix (fr)	 Stellar Labs (us)	 TF1 Publicité (fr)	 Tongji University (cn)

Media planning TV



TF1 Publicité

Bouygues : 32 Mds €, 120 000 collaborateurs

- Bouygues Construction, Colas, Bouygues Immobilier
- TF1, Bouygues Telecom
- Participations dans Alstom



Groupe TF1 : 2.5 Mds €

- TF1 : première chaîne française
- Eurosport : première chaîne sportive européenne



TF1 Publicité : régie publicitaire

- Gère 1.6 Mds € de publicité TV, radios, sites web et mobiles
- Régie TV (1,4 Mds €) : TF1, chaînes thématiques (TNT et payantes)



L'offre pub sur la chaîne TF1

Offre classique « spot à spot »

“Je souhaiterais acheter un spot de 30 sec sur TF1 dans l'écran 20:30 le 15/12/2014 pour un parfum Miss Dior”

Nouvelle offre « FLUO » (2015)

“Pourriez-vous me placer une campagne de 3 semaines sur TF1 avec un budget de 200 000 €, en 15 sec et 25 sec, 60 % du GRP en première semaine, 20 % en Prime.”



OFFRES & TARIFS

JANVIER - JUIN 2015



EN 2015, TF1 PUBLICITÉ RÉ-INVENTE L'ACHAT DES CHÂÎNES TNT-THÉMATIQUES AVEC LA MISE EN PLACE DE FLUO.

FLUO est un mode de commercialisation flexible avec un choix de 27 cibles garanties sur des offres mono-chaîne ou multi-chaîne, permettant de répondre à vos objectifs de ciblage, de médiaplanning et de recherche de contexte affinitaire.

Ainsi FLUO va rendre vos achats plus FLUides tout en Optimisant vos campagnes.

FLUO offre quatre avantages : la simplification de l'achat, la transparence/garantie des prix, la flexibilité/optimisation du médiaplanning et l'accès à une offre de chaînes performantes.

EN 2015, METTEZ DU FLUO DANS VOS CAMPAGNES !

Nouvelle offre FLU0

Une offre avec **audience garantie**

TF1 planifie et garantit **une campagne**, et non plus un spot dans un écran (= offre classique « spot à spot »)

→ TF1 construit la campagne et peut changer les emplacements des spots chaque jour

Avantages de cette planification dynamique :

- Optimiser la qualité de service des clients jusqu'à la diffusion
- Optimiser le revenu jusqu'à la diffusion



FLUO : un client définit sa campagne à l'aide de critères (= buts)

Principaux : budget ou audience visés, répartition de l'audience sur la journée, sur les périodes de la campagne, sur les types de spots.

Secondaires : espacement des spots en journée, équilibrage du nombre de spots par jour, accroître la pression en GRP sur le week-end ou sur une cible, démarrer la campagne par un spot en Prime, etc.

Les critères sont ordonnées, car certains peuvent ne pas être satisfaits.



IDENTITE DU PRODUIT

Groupe annonceur **DANONE**

Annonceur **DANONE**

Produit (libellé) **TAILLEFINE MAGNUM MPI**

Code Produit TF1 **87737 87785**

Contact **Zakiya BOUJIDA**

Cible garantie **Femmes RDA + Enfants**

Cible produit

Commentaire Agence

Le 17/06 : changement de format passage en 26" vs 25".

Le 22/06 : décalage de date passage au 4 juillet.

Commentaire TF1 Publicité
Accepté

Budget estimé : 231 553€

OBJECTIFS DU PLAN

 Version **3**

 Date **22/06/2011**

 Dates de la campagne du **04/07/2011** au **31/07/2011**

 Pression **242** GRP

 Budget Net FO prévisionnel (hors premiums & EP) (**) K€

Formats

 Format n°1 **26** secondes Format n°2 secondes

Répartition par tranches horaires (en % GRP)

Day	57 %	écrans (0300 - 1899)	138 GRP
Access	6 %	écrans (1900 - 1999)	15 GRP
Peak	26 %	écrans (2000 - 2199)	63 GRP
Night	11 %	écrans (2200 - 2799)	27 GRP

Répartition par semaines actives (en nb de GRP)

Semaine 1	du	04/07/2011	au	10/07/2011	57	24%
Semaine 2	du	11/07/2011	au	17/07/2011	62	26%
Semaine 3	du	18/07/2011	au	24/07/2011	61	25%
Semaine 4	du	25/07/2011	au	31/07/2011	62	26%
Semaine 5	du		au			
Semaine 6	du		au			
Semaine 7	du		au			
Semaine 8	du		au			
Semaine 9	du		au			
Semaine 10	du		au			

Répartition des formats (en %)

		Format 1	Format 2
Semaine 1		100	0
Semaine 2		100	0
Semaine 3		100	0
Semaine 4		100	0
Semaine 5			
Semaine 6			
Semaine 7			
Semaine 8			
Semaine 9			
Semaine 10			

(*) Les codes secteurs utilisés sont ceux de la fiche produit

(*) La présence de multi-annonceurs et/ou multi-marques entrainera une majoration du budget

Mesure de la qualité de service

Pour chaque critère, la qualité de service est mesurée via des intervalles de satisfaction (ex : parfait, acceptable, non satisfait)

Classe 1

Taux de servi GRP

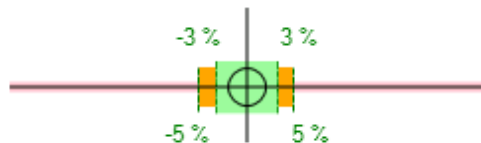

Taux de servi Budget

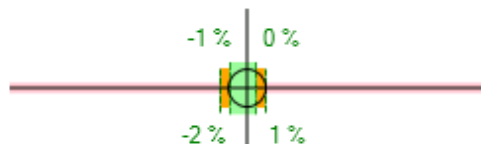

Classe 2

Ecart objectif dayparts

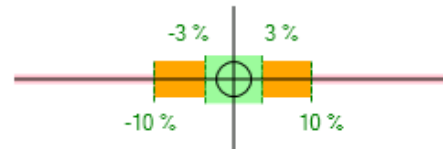

Pourcentage max budget premium : %



Gestion des sous-périodes :

Ecart à l'objectif

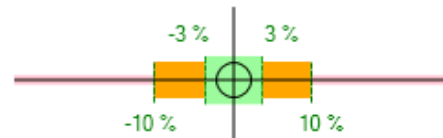

Suivi de la qualité de service

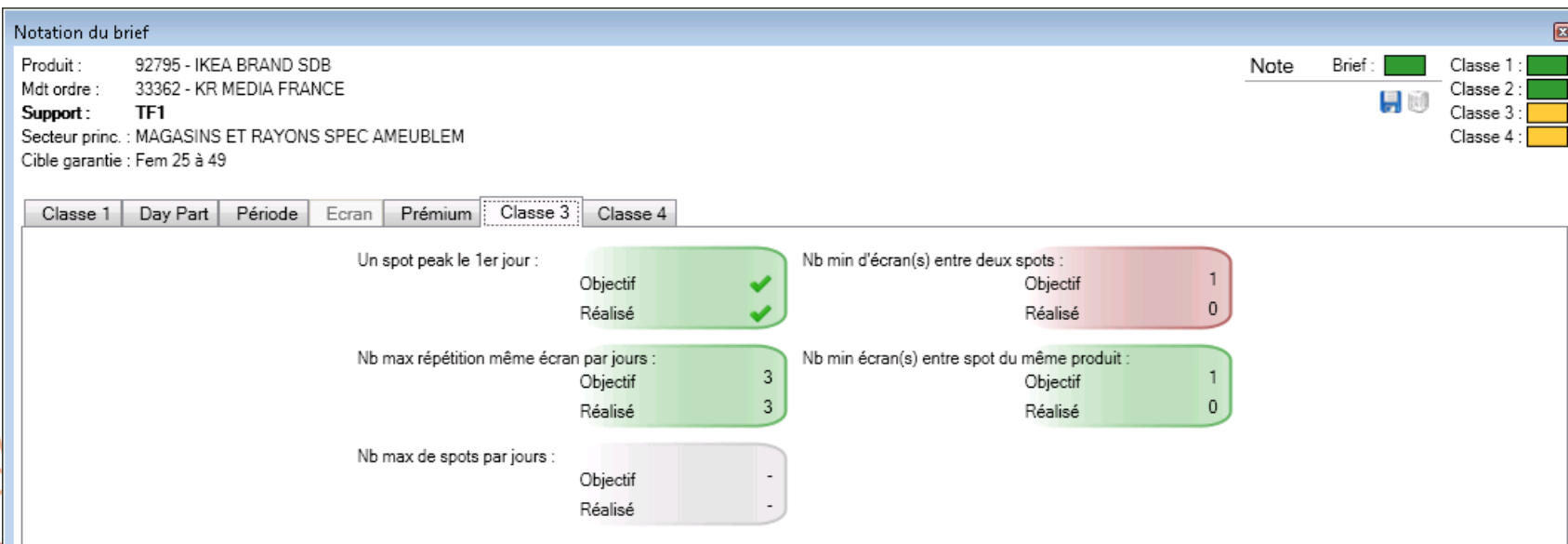
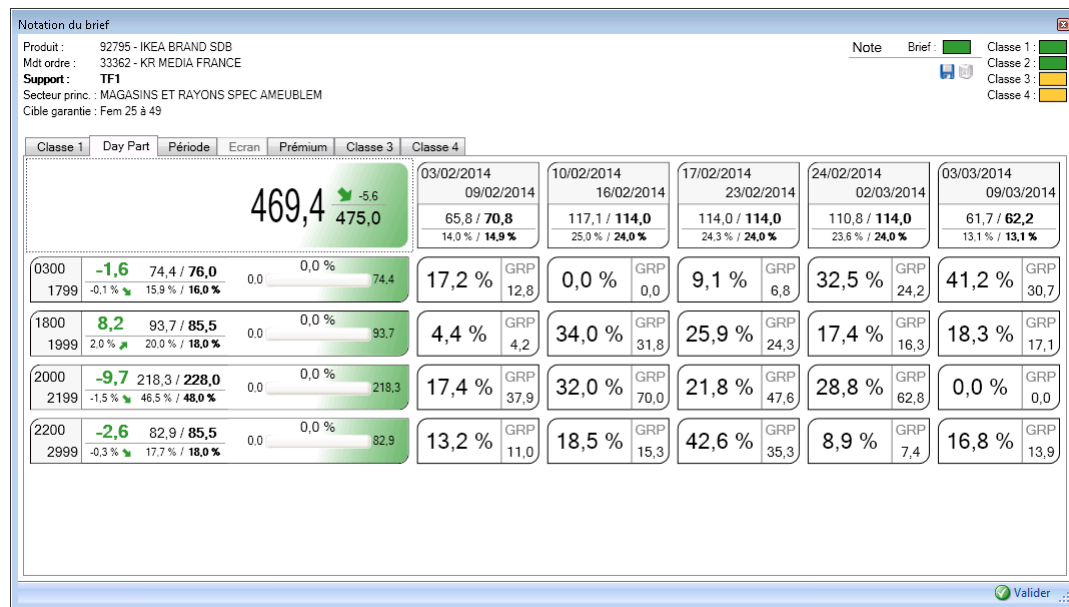
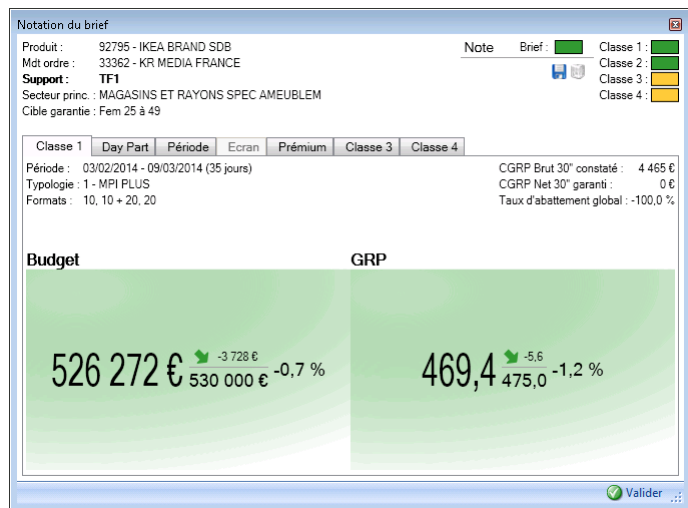

Problème d'optimisation

Placer les spots TV des campagnes données dans les écrans de pub.

Contraintes :

- Ne pas dépasser la capacité de chaque écran (packing)
- Respecter la concurrence entre spots (exclusion mutuelle)

Objectifs :

- 1) Satisfaire au mieux les critères pour chaque campagne (service)
- 2) Maximiser le revenu espéré jusqu'à la diffusion (revenu)

Chaque nuit, campagnes actives + nouvelles sont replanifiées.



Taille du problème

12 millions de variables dont 1.3 millions de décisions binaires

1h de calcul sur un ordinateur standard

Moteur d'optimisation directement basé sur  **LocalSolver**

Exemple:

15 chaînes

24 cibles marketing

500 campagnes

50 000 écrans

100 000 spots placés



Du statique au dynamique

Une histoire qui s'accélère

- 1998 : optimisation de la demande initiale pour TF1 (statique)
- 2004 : optimisation de la construction de packages avec nombre de spots fixé pour les chaînes thématiques (statique)
- 2008 : optimisation mono-campagne sur les chaînes thématiques (à la demande jusqu'à la diffusion)
- 2012 : optimisation multi-campagnes à audience garantie sur la chaîne TF1 (dynamique, automatique et journalière)  LocalSolver
- 2015 : optimisation multi-campagnes et multi-chaînes à audience garantie sur les chaînes thématiques (automatique chaque nuit + à la demande en journée)  LocalSolver



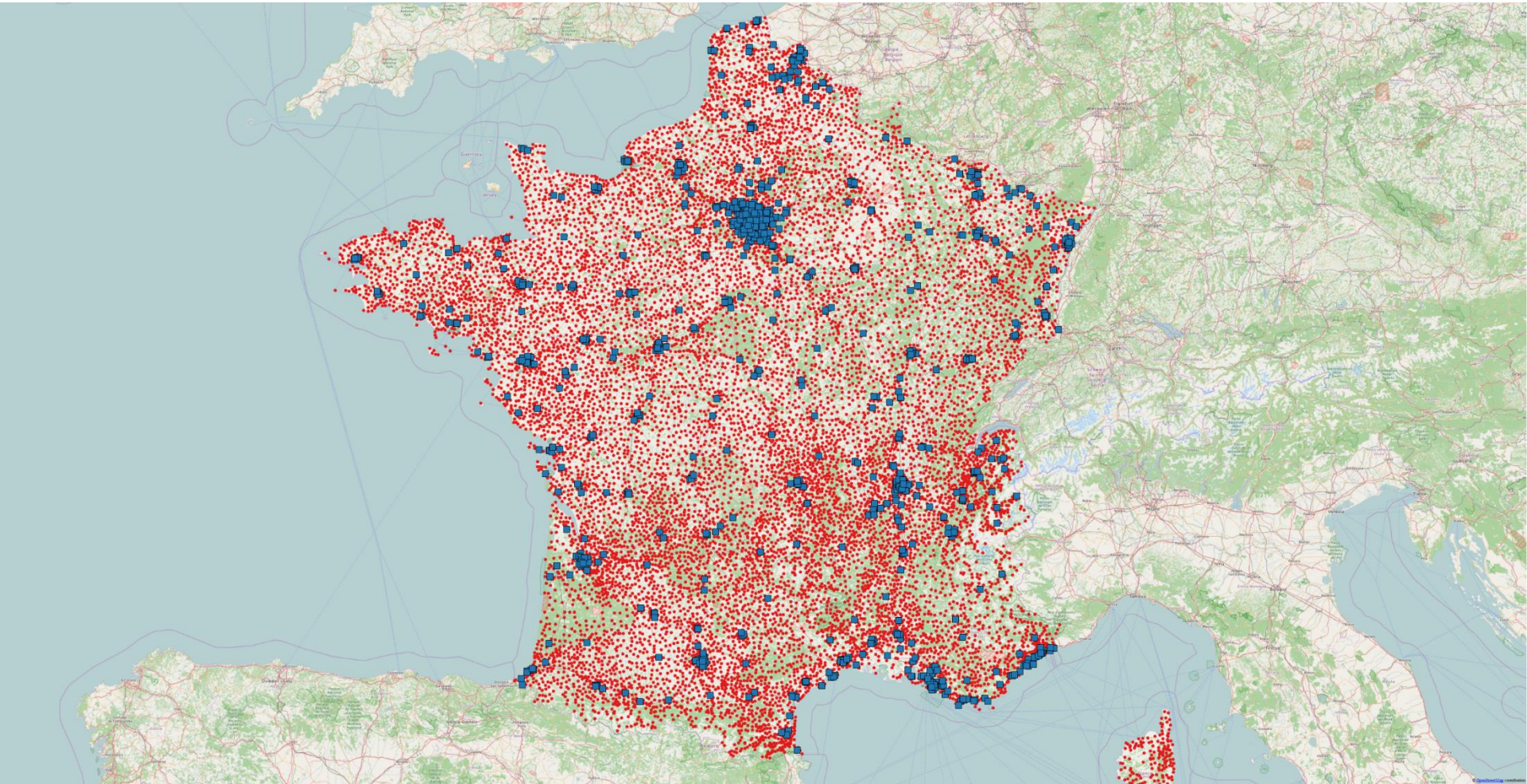



Dimensionnement d'une flotte de méthaniers
et des tournées d'approvisionnement sur 20 ans
Enjeux financiers : Mds €





CAISSE D'ÉPARGNE



CRÉDIT FONCIER

Moteur d'assemblage de prêts immobiliers
5 000 agences, 25 millions de clients



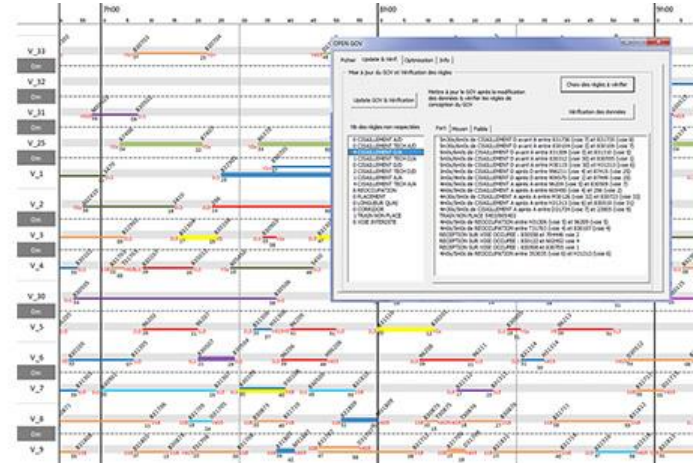

Attribution des quais aux trains
en respectant les contraintes de croisement





Pascoの冷凍生地
サポートします。ベーカリービジネス
業務用冷凍生地ネット通販 送料全国無料



Optimisation des lignes de production
et de la logistique de distribution
pour l'ensemble du Japon

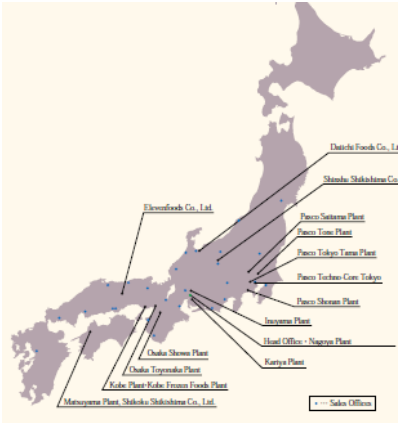

**Pascoの
バラエティ
ブレッド**





STELLAR

Minimisation des temps de vol à vide d'une flotte de jets privés

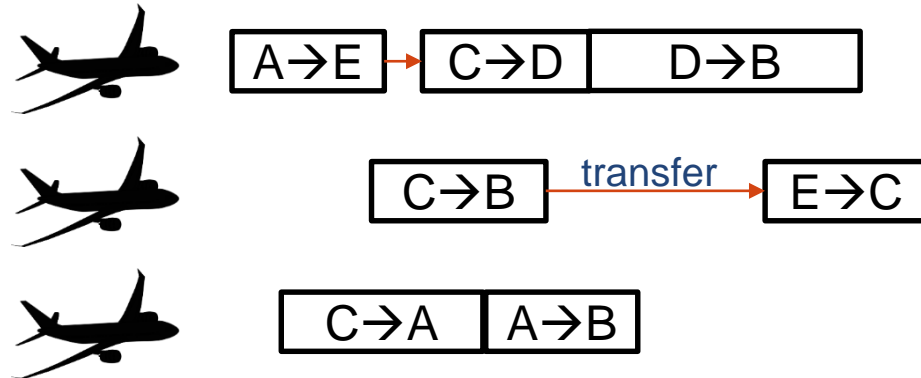
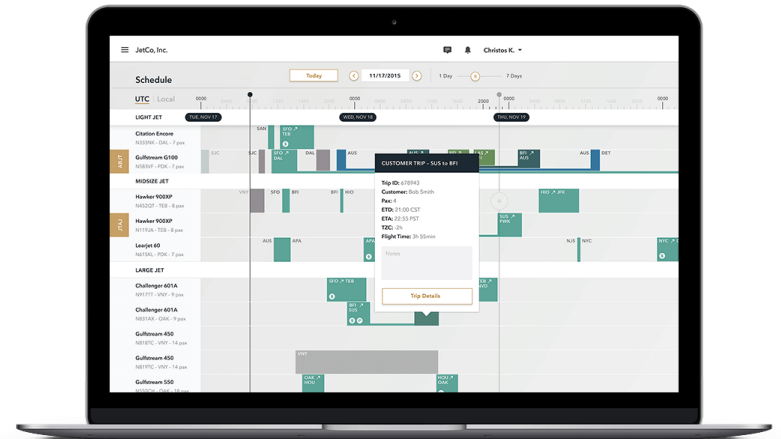

www.stellar.aero



Retour d'expérience



Notre méthodologie

Etapes d'un projet de RO

1. Analyser le besoin du client
 2. Modéliser le problème mathématiquement
 3. Résoudre via des outils (solveurs) ou un algorithme ad-hoc
 4. Présenter les solutions au client puis boucler sur l'étape 1
-

Etape 1: 3 choses à déterminer

- Quels sont les leviers sur lesquels le client peut agir ? (décisions)
- Quelles sont ses contraintes ? (contraintes)
- Que cherche t-il à optimiser ? (objectifs)

→ Bien identifier les décisions est particulièrement important



Notre méthodologie

Etapes 2 et 3 fortement liées

- Modélisation selon l'approche de résolution (outil ou algorithme)
- **Productivité** = choisir la « bonne » approche

Exemple d'approches

- Heuristique constructive (gloutonne)
- Heuristique itérative : recherche locale, algorithmes évolutionnaires
- Enumérative : recherche arborescente, programmation dynamique

Exemple d'outils

- Solveurs LP/MIP
- Solveurs CP
- Solveurs SAT
- Solveurs NLP
- Bibliothèques, frameworks, plateformes (ex: Matlab)



LocalSolver : solveur d'optimisation générique

Problème métier

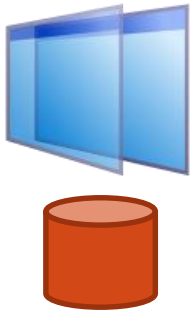

Solution

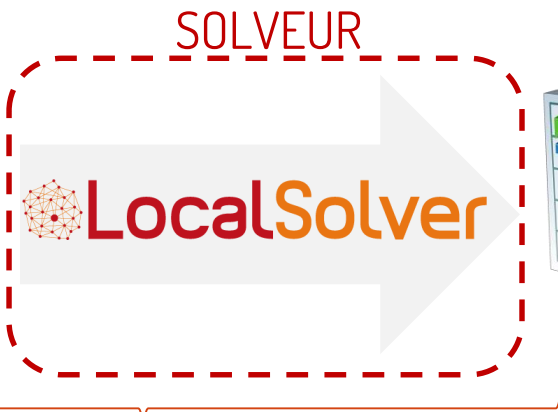
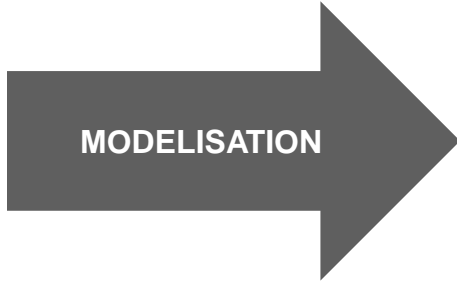
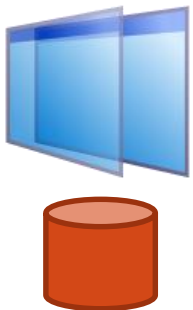
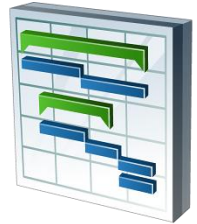

Réduit de 50 % les coûts de développement et de maintenance



Pourquoi LocalSolver ?

Permet de séparer le modèle de l'algorithme d'optimisation

Modèle : défini de manière déclarative en fonction des spécifications

- puissance et simplicité du formalisme de modélisation (non-linéaire)
- facilite la maintenance et les évolutions du modèle

Algorithme : délégué à LocalSolver qui combine de puissantes technologies d'optimisation, fruit de 10 ans de R&D en partenariat avec Aix-Marseille Université et le CNRS

- solutions d'excellente qualité en des temps très courts (minutes voire secondes)
- passage à l'échelle : peut traiter des millions de variables



Nos clés méthodologiques

Prestations rémunérées et cadre juridique

Etudes et logiciels **opérationnels**

Sens du service & communication

Ne pas se focaliser sur la recherche de l'optimum mathématique

Fournir d'abord de bonnes solutions (en des temps courts)

Livrer une 1^{ère} version de votre logiciel **très tôt**

Intégration & données -> vigilance !

Modélisation >>> Résolution

Pas de religion algorithmique

Simplicité = maintenabilité

Pour aimer la RO, mieux vaut aimer l'**informatique**





www.localsolver.com

Swiss Army Knife for math optimization

All-Terrain & All-In-One

Discrete, Numerical, Black-Box

Fast & Scalable

Innovative Resolution Technology



Features

Better solutions, faster

- Provides high-quality solutions quickly (minutes)
- Scalable: able to tackle problems with millions of decisions

Easy to use

- « Model & Run »
 - Rich but simple mathematical modeling formalism
 - Direct resolution: no need of complex tuning
- Innovative modeling language for fast prototyping
- Object-oriented Python, Java, C#, C++ APIs for tight integration
- Available for common platforms: Windows, Linux, Mac OS | 32 or 64-bits



LocalSolver

Quick tour



Parametric optimization

Maximize the volume of a bucket with a given surface of metal

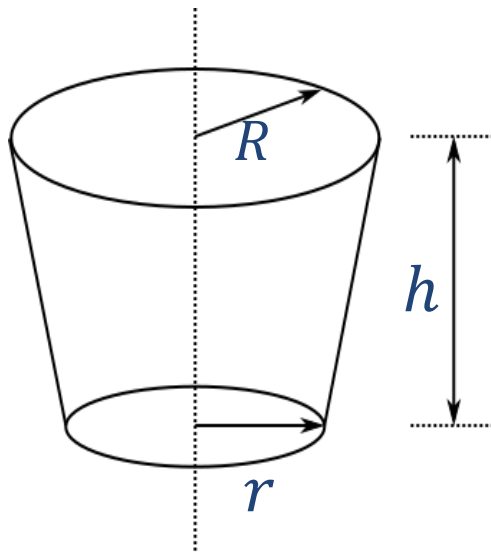

```
function model() {  
  R <- float(0,1);  
  r <- float(0,1);  
  h <- float(0,1);  
  
  V <- PI * h / 3.0 * (R*R + R*r + r*r);  
  S <- PI * r * r + PI*(R+r) * sqrt(pow(R-r,2) + h*h);  
  
  constraint S <= PI;  
  maximize V;  
}
```

$$V = \frac{\pi h}{3} (R^2 + Rr + r^2)$$

$$S = \pi r^2 + \pi(R+r)\sqrt{(R-r)^2 + h^2}$$



P-median

Select a subset P among N points minimizing the sum of distances from each point in N to the nearest point in P

```
function model() {  
  x[1..N] <- bool() ; // decisions: point i belongs to P if x[i] = 1  
  constraint sum[i in 1..N]( x[i] ) == P ; // constraint: P points selected among N  
  minDist[i in 1..N] <- min[j in 1..N]( x[j] ? Dist[i][j] : InfiniteDist ) ; // expressions: distance to the nearest point in P  
  minimize sum[i in 1..N]( minDist[i] ) ; // objective: to minimize the sum of distances  
}
```

Nothing else to write: “model & run” approach

- Straightforward, natural mathematical model
- Direct resolution: no tuning



Mathematical operators

Decisional	Arithmetical			Logical	Relational	Set-related
bool	sum	sub	prod	not	==	count
float	min	max	abs	and	!=	contains
int	div	mod	sqrt	or	>=	at
set	log	exp	pow	xor	<=	indexOf
list	cos	sin	tan		>	disjoint
	floor	ceil	round	iif	<	partition
	dist	scalar		piecewise		

+ operator **call** : to call an external native function which can be used to implement your own (black-box) operator



P-median

Select a subset P among N points minimizing the sum of distances from each point in N to the nearest point in P

```
function model() {  
  x <- set(N) ; // decisions: subset P among the N points  
  constraint count(x) == P ; // constraint: P points selected among N  
  minDist[i in 1..N] <- min( j in x, j => Dist[i][j] ) ; // expressions: distance to the nearest point in P  
  minimize sum[i in 1..N]( minDist[i] ) ; // objective: to minimize the sum of distances  
}
```

Nothing else to write: “model & run” approach

- Straightforward, natural mathematical model
- Direct resolution: no tuning



Traveling salesman

Find the shortest tour that visits N cities exactly once

```
function model() {  
  x <- list(N) ; // order n cities {0, ..., n-1} to visit  
  constraint count(x) == N; // exactly n cities to visit  
  minimize sum[i in 1..N-1]( Dist[ x[i-1] ][ x[i] ] ) + Dist[ x[N-1] ][ x[0] ] ; // minimize sum of traveled distances  
}
```

Could you imagine a simpler model

- Natural declarative model → straightforward to understand
- Compact: linear in the size of input → highly scalable (1 million nodes)



Vehicle routing

Find the shortest routes of a fleet of K vehicles with a given capacity to deliver N customers

```
function model() {  
  routes[1..K] <- list(N) ; // for each vehicle, the list of visited clients  
  constraint partition[k in 1..K]( routes[k] ); // each client is visited once  
  for [k in 1..K] {  
    route <- routes[k];  
    n <- count( route );  
    constraint sum( 0..n-1, i => demands[ route[i] ] ) <= capacity; // truck capacity constraint  
    distances[k] <- sum( 0..n-2, i => distance( route[i], route[i+1] ) ) // sum of distances between each pair  
      + distance( depot, route[0] ) + distance( route[n-1], depot ); // of clients along the route  
  }  
  minimize sum[k in 1..K]( distances[k] ); // minimize sum of traveled distances  
}
```



Black-box optimization

Context

- Function f without analytical form (external code or library)
- Maybe be costly to evaluate (minutes or even hours)
- f may be non-smooth, noisy, or even non-deterministic
- f defined over continuous, boolean, integer, set & list variables
- With arbitrary constraints

Engineering applications

- Product or system design -> parametric optimization
- Simulation optimization

$$\min f(x)$$
$$x \in [x^L, x^U]$$

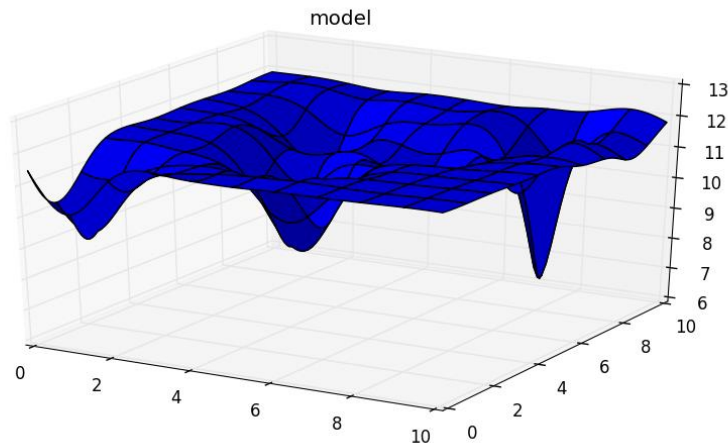

Smart APIs

C++ ISO

Java 5.0

.NET C# 2.0

Python 2.7, 3.2, 3.4

```
##### optimal_bucket.py #####

import localsolver
import sys

with localsolver.LocalSolver() as ls:

    PI = 3.14159265359

    #
    # Declares the optimization model
    #
    m = ls.model

    R = m.float(0,1)
    r = m.float(0,1)
    h = m.float(0,1)

    # Surface constraint
    # surface = PI * r^2 + PI*(R+r) * sqrt((R-r)^2 + h^2)
    surface = PI*r*r + PI * m.sqrt((R-r)**2 + h**2) * (R+r)
    m.constraint(surface <= PI)

    # Maximize volume
    # volume = PI * h/3 * (R^2 + R*r + r^2)
    volume = PI * h/3 * (R**2+ R*r + r**2)
    m.maximize(volume)

    m.close()

    #
    # Param
    #
    ls.param.nb_threads = 2
    if len(sys.argv) >= 3: ls.create_phase().time_limit = int(sys.argv[2])
    else: ls.create_phase().time_limit = 6

    ls.solve()
```



LocalSolver

Case studies



Car sequencing

Smoothing car production loads along the assembly line

2005 ROADEF Challenge <http://challenge.roadef.org/2005/en>

Large-scale instances

- 1,300 vehicles to sequence
- 400,000 binary decisions



Problème également traité chez **PSA PEUGEOT CITROËN** 



Asset management

Street lighting maintenance planning



« Illuminate better with less energy »

- Plan the replacement and maintenance of street lighting fixtures over 25 years
- Taking into account costs, resources, energy consumptions, failure rates, etc.

Large-scale combinatorial optimization

- Thousands of streets
- Tens of thousands of lighting fixtures
- Nonlinear model with 1,000,000 variables



LocalSolver based software used interactively
in each bidding process

Rounding consolidated accounts

How rounding at best a financial data cube to be consolidated?

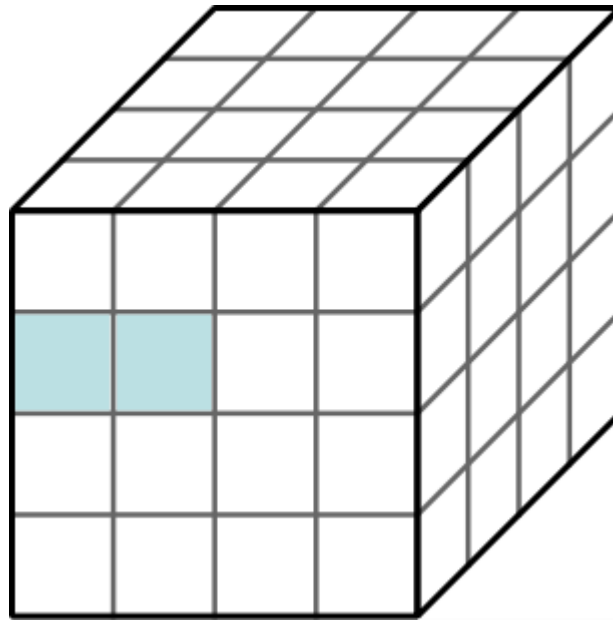

Sum of rounded amount is not equal to the rounded sum



Media planning

Selling advertising spaces in Paris Underground



60,000 ad points (= faces) to partition into products from 100 to 500 faces

- Covering a maximum of stations
- Balanced according to the traffic
- + a dozen of quality criteria

Huge partitioning problem solved in 1 minute

 LocalSolver



Supply chain optimization



Global supply chain optimization

- Both production and logistics optimization
- 15 factories, each with several production lines
- More than 100 distribution centers to deliver

A challenging context for LocalSolver

- 32,000,000 variables including **8 million binaries**
- 1,000,000 constraints, 16 lexicographic-ordered objectives
- Vain attempts to solve the problem with MIP solvers
- LocalSolver finds high-quality solutions in 3 minutes

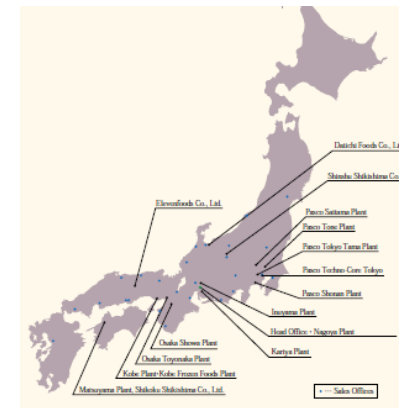

Uberising private jet business

Flights to plane assignments

STELLAR
www.stellar.aero

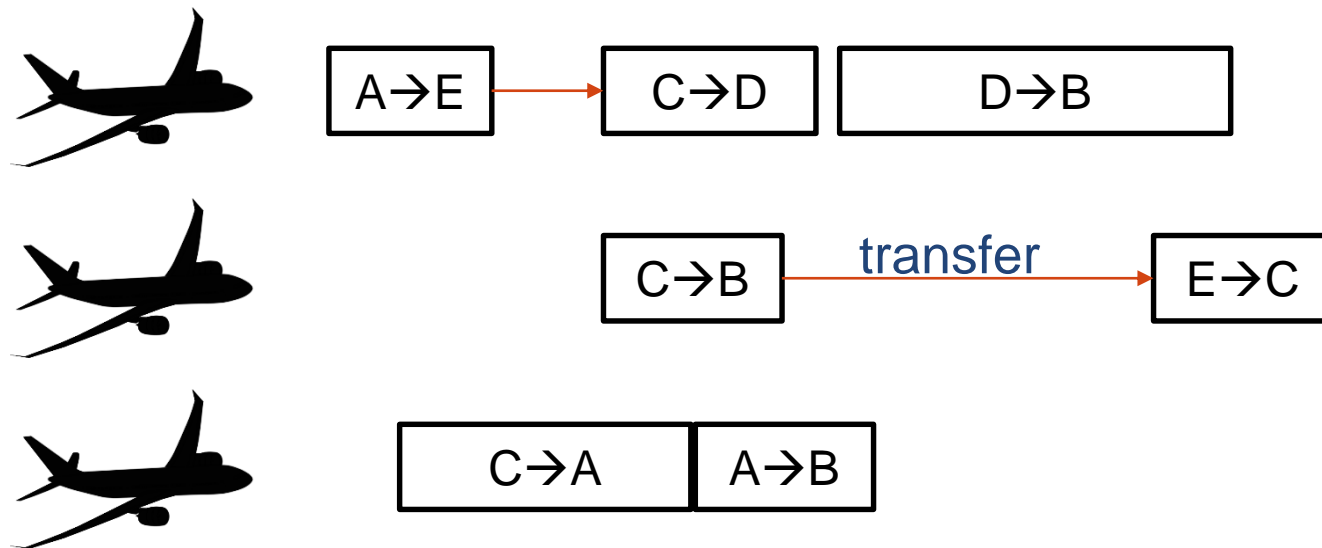

A solution is a partition of flights into K lists (one per plane)

The goal is to minimize the total transfer times



Mechanical system design

Designing sailboat weathervanes



Context

- Used to measure the wind, to drive sailboats
- High precision needed in nautical competition

Small but highly nonlinear problem

- 4 continuous decisions
- Precision: 0.1 millimeters
- 2 criteria optimized

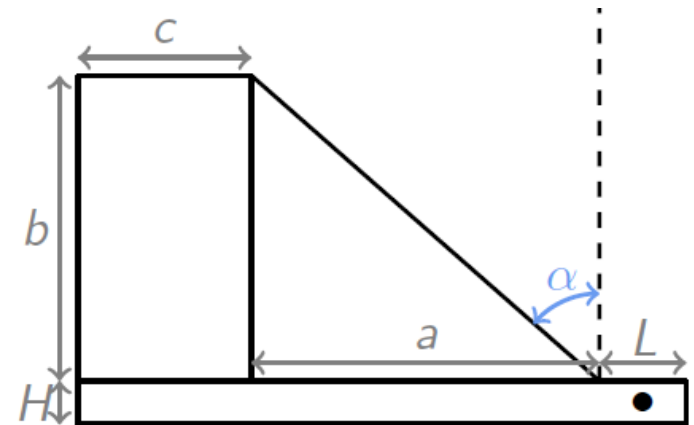

Engine calibration

Calibrate engine cartography

- Nonlinear parametric models (maps)
- Very large scale: 5,000+ parameters
- Plugged to Matlab Simulink statistical models: 10 calls per sec
- 1st objective: fitting experimental measures
- 2nd objective: smoothing the cartography (avoiding large variations)
- LocalSolver allows to reduce computation time **from 1 month to 1 day**



RENAULT

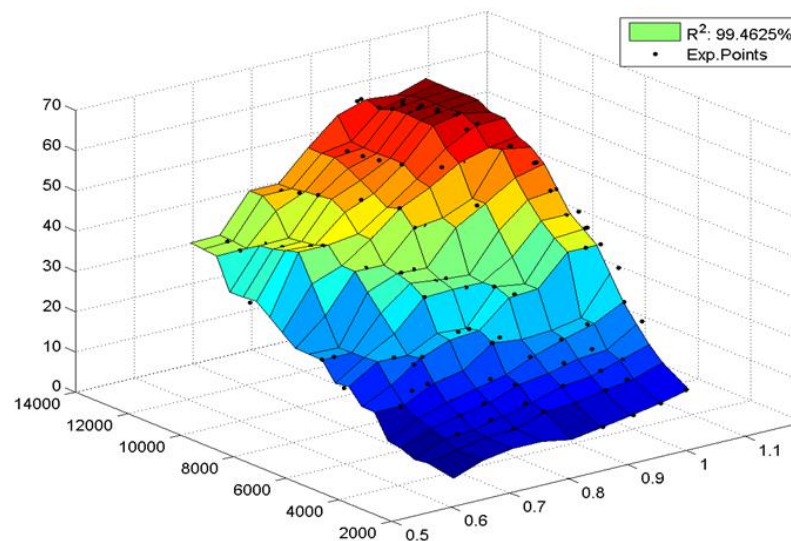

Agronomic system optimization

Optimal fertilization of agricultural parcels



How to best fertilize soils from mineral and organic fertilizers?

Highly-nonlinear dynamic system

- Nonlinear dynamics of N, C, K over time
- 3000+ on/off and continuous parameters
- Analytical or simulation-based (Century)

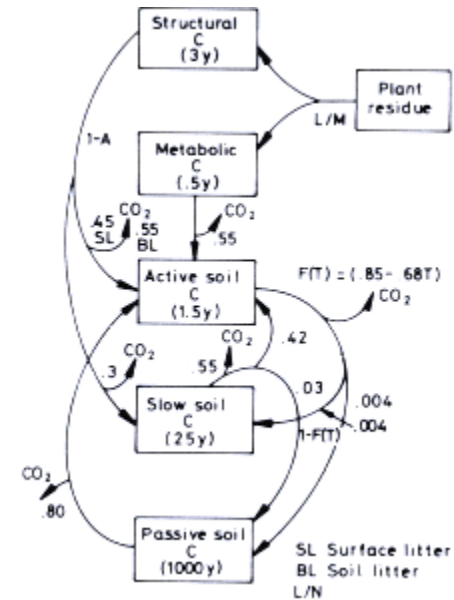



www.localsolver.com